



# CHILD CARE LICENSING PROGRAM

Division of Public Assistance  
Child Care Program Office

Office Use Only

## Get Out Alive! Disaster Preparedness and Emergency Evacuation Plan

A licensed child care facility must have a disaster preparedness and emergency evacuation plan that includes evacuation procedures that will ensure the complete evacuation of children in care, including children with limited mobility, within 150 seconds (2 ½ minutes). For further information, refer to 7AAC 10.1010 (Licensed Providers). **This form is provided for your convenience to document your facility’s disaster preparedness and emergency evacuation plan or to use as a guideline for developing your own plan.** All of the requirements listed in this guideline are required as part of your disaster preparedness and emergency evacuation plan.

**The disaster preparedness and emergency evacuation plan requires both a floor plan mapping your child care facility’s evacuation routes and a written plan describing the procedures to be followed.**

**The floor plan must include identification of:**

- Smoke detectors, fire extinguishers, and carbon monoxide detectors;
- Escape routes from every room with doors and windows clearly marked for each level of the child care facility; and
- Specified meeting place outside the facility.

**The written plan must describe detailed procedures the child care facility will follow, including:**

- How the facility will ensure evacuation of everyone within 150 seconds, including children under 30 months of age, children with limited mobility, and children who otherwise may need assistance in an emergency, including a child who is mentally, visually, or hearing impaired;
- What the facility will do during emergency situations or natural disasters that may affect the facility, including, as appropriate, fire, tsunami/flooding, earthquake emergencies, lock-down, shelter in place and etc.;
- The relocation site and plan to reunify children with their parents in the event of the need to relocate due to an evacuation, and a continuity of care plan – the facility’s plan on how they will continue care after a disaster;
- How the facility will conduct and record monthly emergency evacuation drills and ensure participation of all employees who are on duty during the scheduled drill;
- The location of disaster and first aid kit(s); and
- Training of staff on the implementation of the Disaster Preparedness and Emergency Evacuation Plan.

Sample Floor Plan Evacuation routes (each floor of child care facility must be drawn separately)

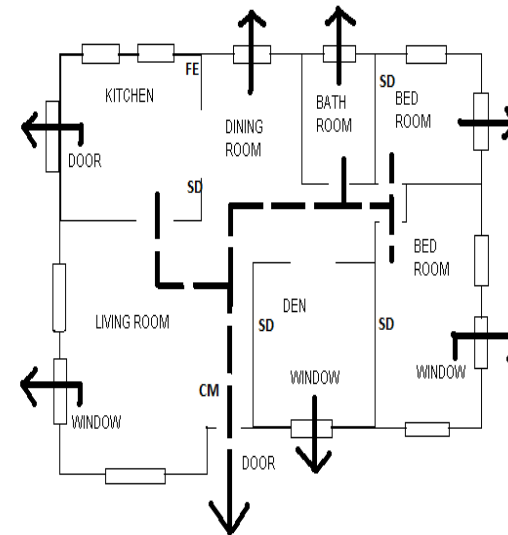

FE= Fire Extinguisher  
SD= Smoke Detector  
CM= Carbon Monoxide Detector

Facility Name: \_\_\_\_\_

Physical Address: \_\_\_\_\_

Facility Floor Plan:

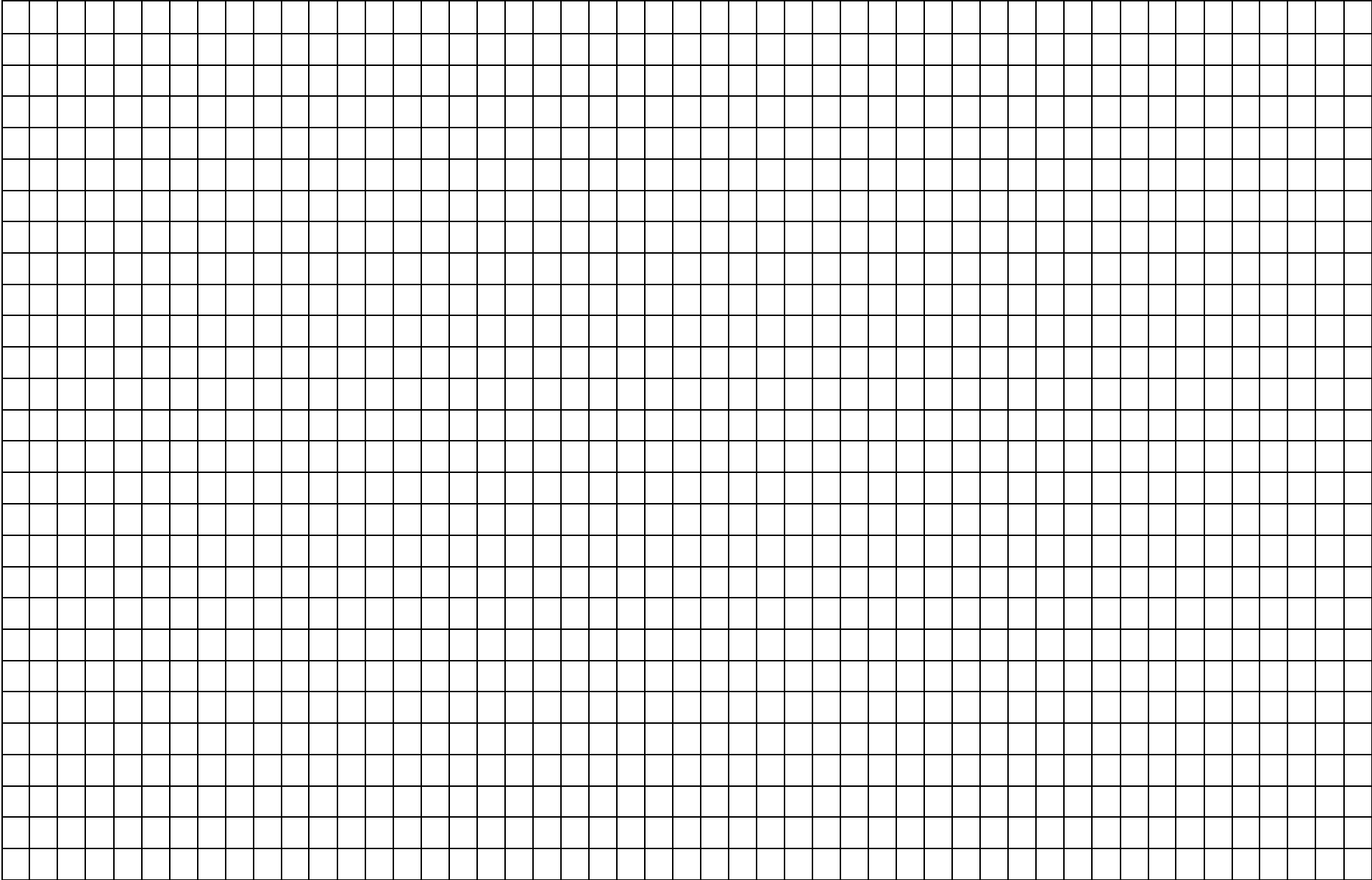

Facility Name: \_\_\_\_\_

Physical Address: \_\_\_\_\_

Facility Written Plan:

---

---

---

---

---

---

---

---

---

---

---

---

---

---

---

---

---

---

---

---

---

---

---

---

---

---

---

---

---

---

---

---

---

---

---

---

---

---

---

---

---

---

---

---

---

---

---

---

---